

DUCATI actuator model HC518 Installation diagram

- HC518
 - HC518 FC (with on board open& closed position mechanical limits)
- each model is also available in 24V version

Maximal wing dimension:

Maximal wing lenght: up to 3m/ 8,5 ft

Maximal wing weight: up to 300kg/ 760lb

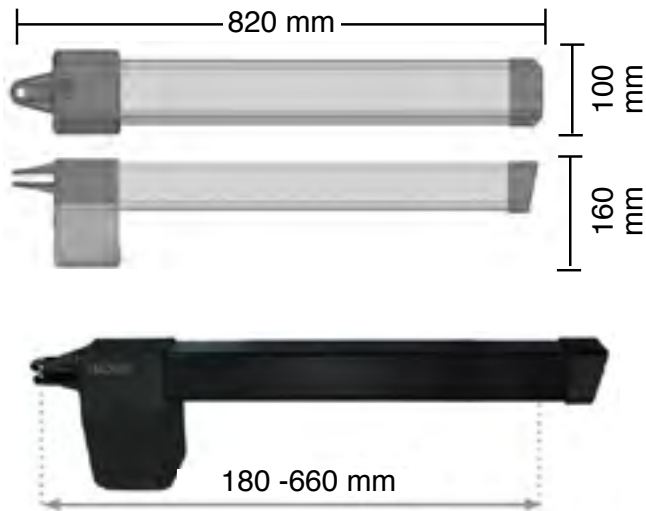

Supplied fixing bracket:

choose the hole most suitable to your gate.
You can cut the plate if necessary

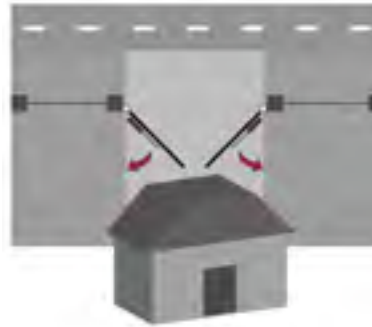
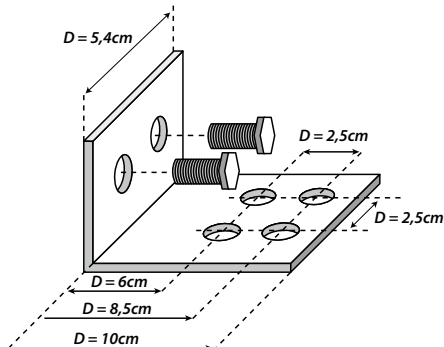

PULL TO OPEN OPERATION (opens towards inside)

This means the gate operator is mounted on the inside of the property and pulls your gate in towards the property to open.

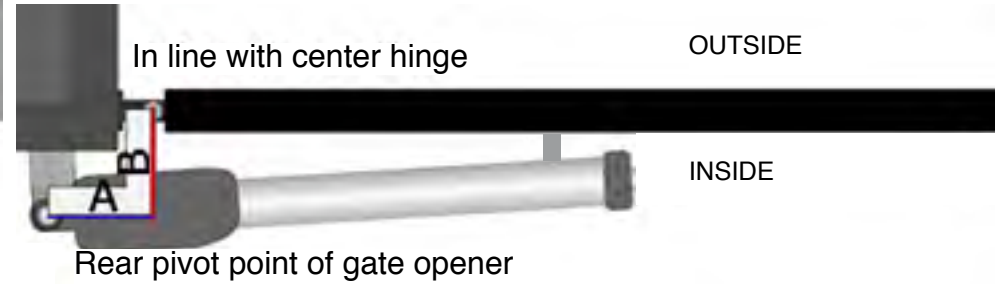

maximal dimension	A=10 cm	A=12cm	A=14 cm	A=18 cm
B= 10cm	108°	115°	120°	100°
B= 12cm	105°	112°	100°	100°
B= 14cm	103°	109°	98°	/
B= 16cm	101°	97°	90°	/
B= 18cm	97°	/	/	/
B = 22 cm	90 °	/	/	/

METRIC CONVERSION

1 cm = 1/2" = 0,3"
 10 cm = 4"
 12 cm = 4 3/4" = 4,7"
 14 cm = 5 1/2" = 5,5"
 16 cm = 6 1/5" = 6,2"
 18 cm = 7"



PUSH TO OPEN OPERATION (opens towards outside)

If your driveway slopes up after the gate, preventing it from swinging in. This means the gate operator is mounted on the inside of the property and pushes your gate out away from the property. Warning: only compatible with telescopic tube actuators, Check the overall dimensions before installation.

Warning:remember to reverse the polarity of the motor cables when connecting to the electronic board

NOT POSSIBLE WITH THIS ACTUATOR MODEL: IT REQUIRES TELESCOPIC ACTUATORS