

DUCATI General installation diagram

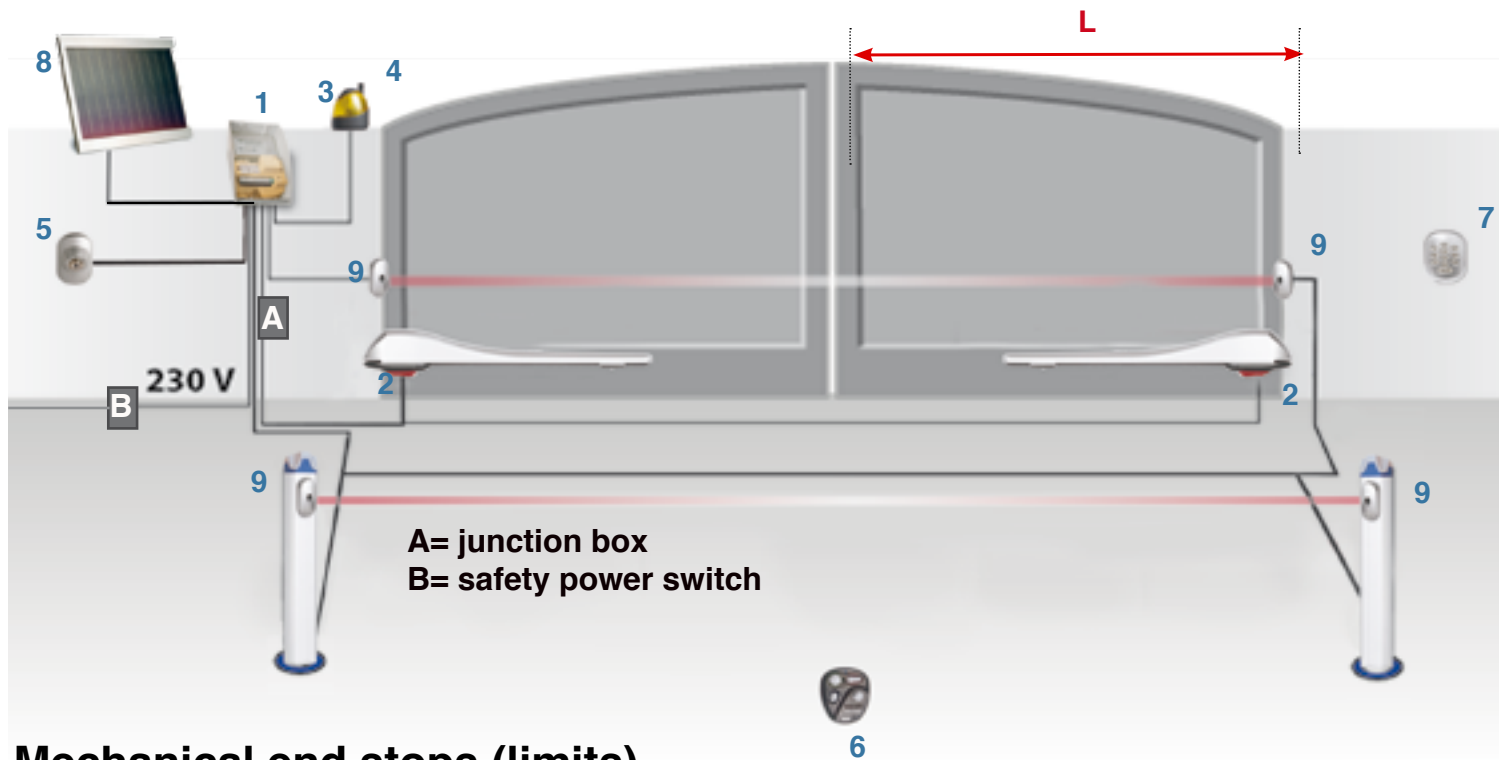

- 1= Control box with containing electronic board with on board radio receiver, toroidal transformer, integrated battery housing compartment.
- 2 = actuators
- 3 = blinking light
- 4 = external antenna (if supplied)
- 5 = key switch
- 6 = radio remote control
- 7 = radio keypad (if supplied)
- 8 = solar panel (if supplied)
- 9 = pair of photocells (if supplied)
- L= wing lenght

A= junction box
B= safety power switch

WARNING: angle of incidence

To ensure a perfect lock of the gate when closed, the actuator must be installed in way to have an angle of incidence to the gate wing in closed position. a greater angle ensu- res greater tightness

Mechanical end stops (limits)

It is mandatory that your gate has mechanical limits fixed on the ground. The limits must stop the gate wings in the closed and open position of each wing. Your gate must be provided with mechanical end stops to be automated. The end sops on the floor can only be omitted in case of gate opener supplied with integrated limits (FC versions). Ducati's gate openers are conceived to stop by amperometric detection. When the gate wing touches and pushes on the mechanical limit (end stop), an amperometric increase is detected by the control board and motor stops. An imperceptible drive reversal draws pressure from the gears of the engine to preserve its life

Warning: make sure not to use the full actuator stroke as the gate wing must stop by pressing on a mechanical end limit (fixed on the ground or FC onboard limit) before the actuator reaches the end of it's stroke.

Warning: if you purchased an FC version actuator, check whether the integrated limit can be used for the open or closed gate position: in fact, not all FC-actuators have double end travel for both positions gate open + gate closed. The use of the integrated travel limit also depends on the opening direction of the gate (push-to-open or pull-to-open).

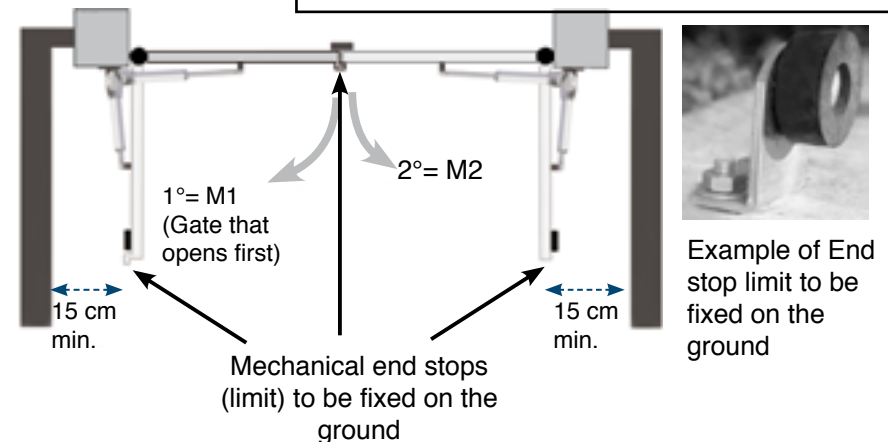

PULL TO OPEN OPERATION (gate that opens towards inside)

This means the gate operator is mounted on the inside of the property and pulls your gate in towards the property to open.

Warning: Each actuator model has limits to the use of measurements A and B. Therefore, verify the conformance of the actuator model with the size of your structure (see following pages the measurement limits A and B for each actuator model). The greater the distance between the gate hinge and the inner edge of the pillar, the longer the chosen actuator will be. It is recommended to install actuators with a certain incidence angle over the gate (not too parallel to the gate itself) for better mechanical performance.

A and B measure the distance between the gate hinge and the rotation center of the actuator (respectively on longitudinal axis and transversal axis). These measurements determine the maximum opening gate and opening speed of the gate. Check the A & B limits for each actuator model in the following pages.

CAUTION: It is recommended not to use the entire stroke of the drive and to install actuators with a certain incidence angle over the gate.

CAUTION.:The gate opening speed depends on the length of the actuator's run used. The less run (stroke) you use, the faster the gate will open.

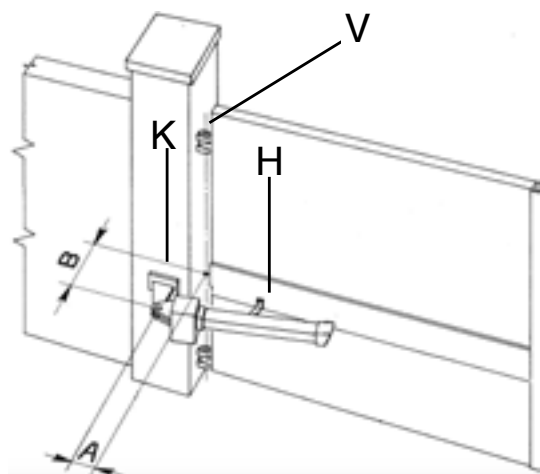

Pillar dimension:

How this influences your gate opener system. Determinate the ideal A & B measure

■ **A=** distance between the hinges of the gate and the actuator's post fixing pin. This distance can be chosen by the user. It is recommended to use a measure similar to the "B" measure.

■ **B=** is the most relevant measure and determines gate opening speed and max. opening angle. it's determined by the pillar dimension + fixing bracket.

Shorter B measure determines faster opening of your gate.

If you require major opening angle choose a short B measure and longer A measure

V= gate hinges

K = post fixing bracket

H = front fixing bracket

Longer telescopic actuators, allow better mechanical operation given by the greater strength of the lever.

Carefully evaluate the size of the pillars in relation to the tables that you will find in the pages that present the limits of use and

PUSH TO OPEN OPERATION (opens towards outside)

The gate opener is mounted on the inside of the property and pushes your gate out away from the property. PUSH-TO-OPEN.

Check the overall dimensions before installation.

It is recommended not to use the entire stroke of the drive and to install actuators with a certain incidence angle over the gate

Warning: use of telescopic actuators is recommended.

Warning: remember to reverse the polarity of the motor cables when connecting to the electronic board

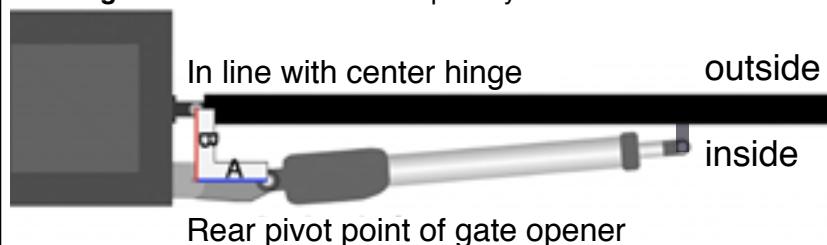

■ **A=** this measure must allow the actuator can open the gate wing at 90 °.

■ **B=** This measure allows the actuator mounting. Compare it to the actuator dimension

Longer telescopic actuators, allow better mechanical operation. Make sure that the gate do not open onto a public passageway. It is advisable to prepare a plant with safety photocells to be placed in such a way that the doors, opening towards the outside do not create damages to things and people who are on the outside of the property, such as parked vehicles.

DUCATI HC612 actuator's installation diagram

- HC612
 - HC612 FC (with on board open position mechanical limit)
- each model is also available in 24V version



Maximal wing dimension:

Maximal wing lenght: up to 5m/ 16 ft
 Maximal wing weight: up to 500kg/ 110lb

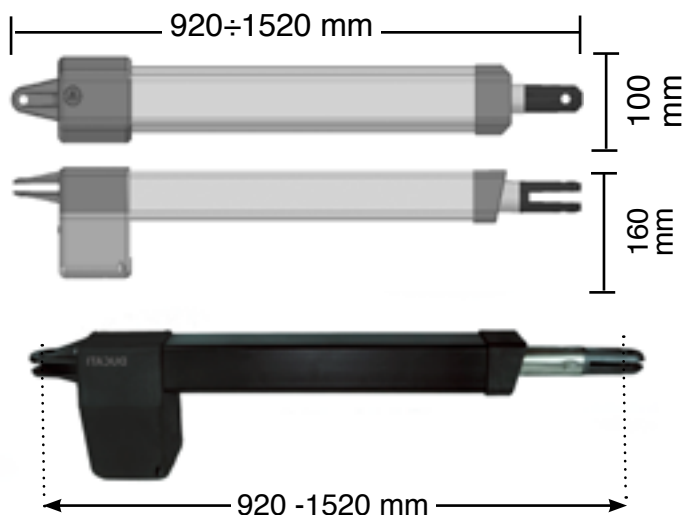

Supplied fixing bracket:

choose the hole most suitable to your gate. you can cut the plate if necessary

Post fixing

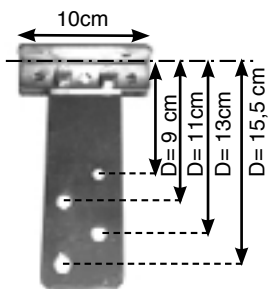

Front fixing

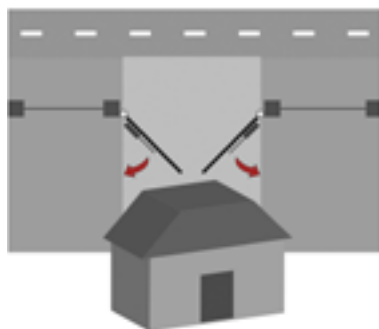
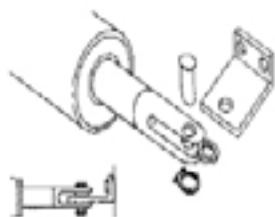

PULL TO OPEN OPERATION (opens towards inside)

This means the gate operator is mounted on the inside of the property and pulls your gate in towards the property to open.

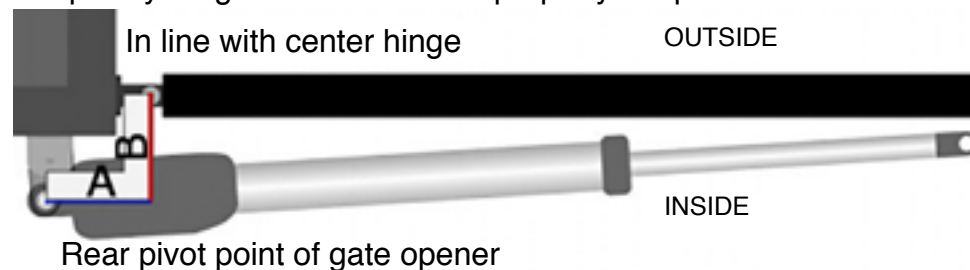

METRIC CONVERSION

- 1 cm = 1/2" = 0,3"
- 10 cm = 4"
- 12 cm = 4 3/4" = 4,7"
- 14 cm = 5 1/2" = 5,5"
- 16 cm = 6 1/5" = 6,2"
- 18 cm = 7"
- 20 cm = 7 7/8" = 7,87"
- 25 cm = 9 3/4" = 9,8"
- 35cm = 13 4/5" = 13,7"

TAB	A= 8cm	A= 10cm	A= 12cm	A= 14cm	A= 16 cm	A= 18cm	A= 20cm	A= 22cm	A= 24cm	A= 26cm	A= 28cm
B= 8cm	16 sec/97°	18sec/110°	21sec/118°	23sec/125°	23sec/130°	24sec/135°	26sec/137°	27sec/115°	31sec/108°	32sec/103°	32sec/105°
B= 10cm	18sec/98°	19sec/107°	22sec/114°	23sec/121°	25sec/127°	27sec/131°	27sec/125°	29sec/115°	31sec/108°	32sec/103°	33sec/99°
B= 12cm	20sec/98°	23sec/105°	24sec/112°	26sec/118°	27sec/124°	29sec/127°	30sec/120°	33sec/110°	34sec/104°	35sec/100°	369sec/96°
B= 14cm	21sec/95°	24sec/103°	25sec/108°	27sec/105°	28sec/120°	30sec/125°	32sec/111°	33sec/105°	35sec/99°	36sec/95°	37sec/93°
B= 16cm	23sec/94°	25sec/102°	28sec/108°	30sec/103°	31sec/118°	33sec/113°	34sec/102°	35sec/98°	37sec/94°	38sec/90°	
B= 18cm	26sec/94°	27sec/100°	29sec/106°	32sec/111°	33sec/115°	34sec/105°	36sec/97°	36sec/93°	38sec/90°		
B= 20cm	28sec/94°	30sec/100°	32sec/105°	34sec/109°	35sec/103°	37sec/96°	40sec/90°				
B= 22cm	29sec/93°	33sec/99°	33sec/103°	34sec/106°	37sec/95°	38sec/90°					
B= 24cm	32sec/93	34sec/99	36sec/102	37sec/93°							
B= 26cm	34sec/93°	36sec/98°	37sec/92°								
B= 35cm	38sec/93°										

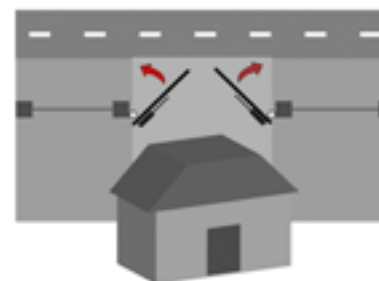

PUSH TO OPEN OPERATION (opens towards outside)

If your driveway slopes up after the gate, preventing it from swinging in. This means the gate operator is mounted on the inside of the property and pushes your gate out away from the property. Warning:remember to reverse the polarity of the motor cables when connecting to the electronic board

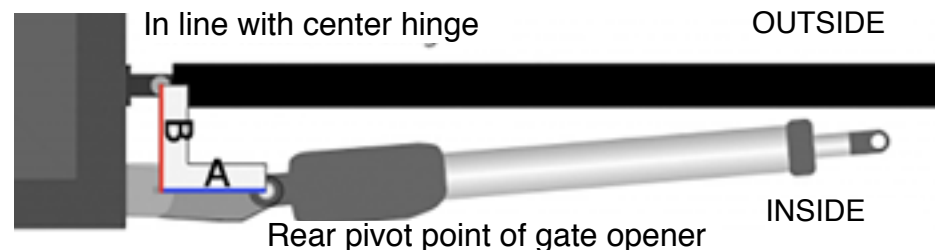

A = min. 8cm
 B = min. 8cm max. 14cm

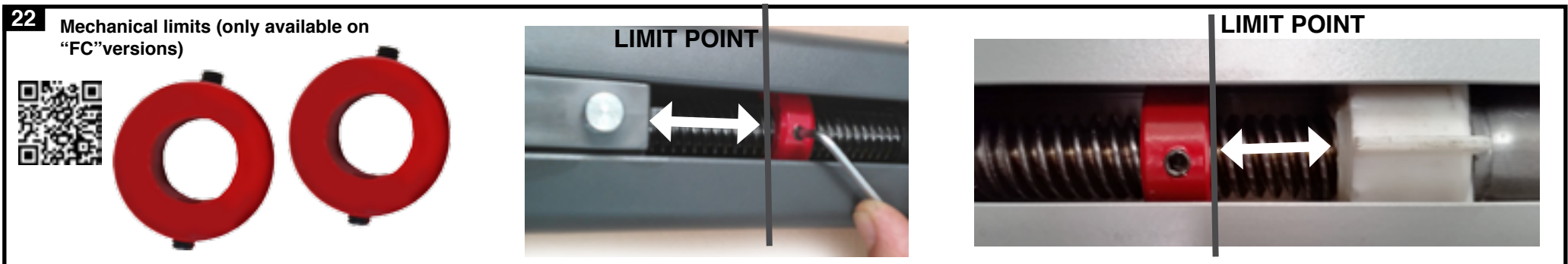
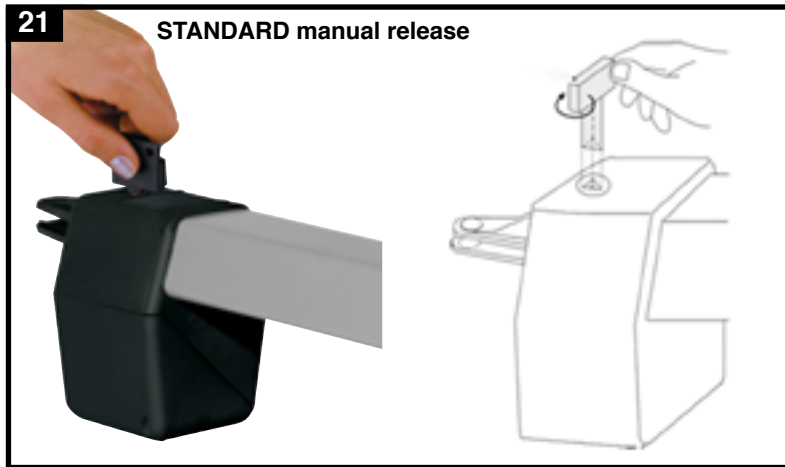
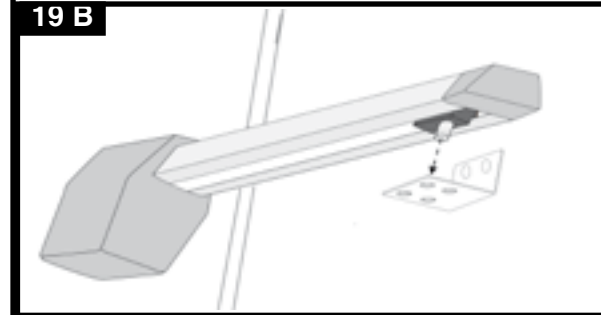
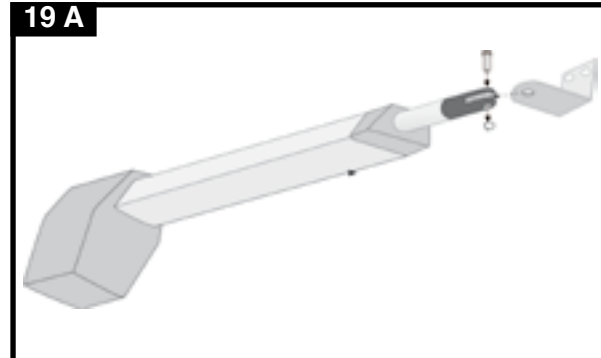
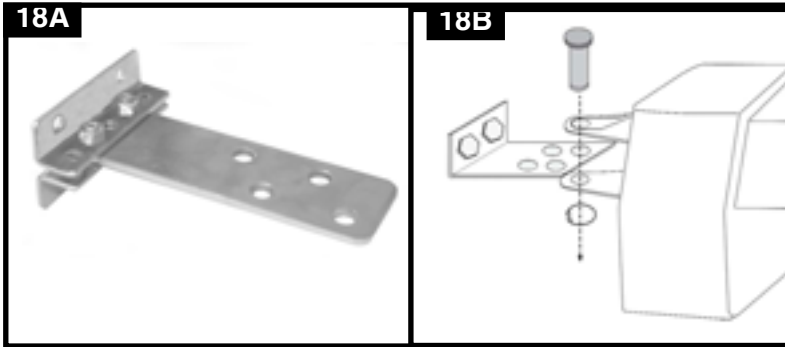

DUCATI Preliminary safety warnings and important informations

1. GENERAL CHARACTERISTICS and PRELIMINARY WARNINGS

The products described in this manual are intended to be used to automate hinged swing gates for residential/ commercial or industrial use, within the limits of use and size provided for each model.

Incorrect installation can cause serious injuries. **Before installing the automation you need to carefully read all the parts of the manual.** If in doubt, stop installation and request clarification from the DUCATI HOME Assistance Service.

 **WARNING!** the gate opener is just one of the components that once installed on the gate forms the automatic gate machine.

Make sure that the structure, that consists of pillars/ wall/ posts, hinges and gate, in perfect condition, perfectly installed, solid and robust. Check that the structure is compatible with the size of the automation and with the limits of use for the selected gate opener. Pay attention to correctly install each component of the gate opener.

 **A gate opener can not correct defects or structural problems of the gate** or other component of the structure. If the installation is not carried out correctly, it is not possible to guarantee the proper functioning of the automatic gate system, neither respect of safety norms.

We recommend installation anti-fall cables to prevent accidents caused by the physical fall of the gate.

The structure on which you are installing must be constructed in a workmanlike manner in accordance with local regulations and satisfy all safety requirements. The automation can not correct defects in the structure. Check that the gate leaves are perfectly balanced, that the hinges are in perfect condition and that the facility is fully operational and complies with safety regulations. Gates with structural problems should not be automated **Warning:** Ducati actuators are designed to be installed to be used indifferently on the right or left leaf of the gate.

 **WARNING!** Any use other than those described in this manual is to be considered improper and prohibited!

Ducati's electromechanical actuators are provided with DC motor, worm screw gear. The motor must be run by a compatible original "DUCATI HOME automation" control unit only.

The actuator stops its movement by means of an amperometric detection system as the gate wing reach a mechanical end stop fixed on the ground to set the open and closed position limit of each wing (only special FC version actuators are provided with on board mechanical end limit).

In case of obstacle detection, safety is also ensured by the amperometric detection system in compliance with EN laws.

In case of power failure (black-out), the actuators are provided with a manual release system by trilobed key.

Warning: to operate the manual release system is required to operate on the actuator witch is installed inside the property, it is therefore advisable to provide an independent pedestrian entrance.

Pages 4-5: The table shows the compositions of each kit, including the corresponding actuator model and control board model.

Page 6: the table shows the technical characteristics and application limits of each actuator model.

Page 7: the table shows the characteristics and comparison of each Control Box (electronic board).

Page 8-9: shows the general installation diagram as well as important information about the requirements of the structure

Pages 10-22 shows each single actuator model installation diagram, limits and overall dimension.

 **IMPORTANT:** Before proceeding with installation carefully read the following preliminary warnings

2. SAFETY WARNINGS

 **Warning ! READ AND FOLLOW ALL INSTRUCTIONS** contained in this installation and use manual. DUCATI gate openers have been designed and tested to offer safe service at condition they are correctly installed, operated, maintained and tested in strict accordance with the instructions and warnings contained in this manual. Failure to meet the requirements stated in this instruction manual could cause severe injury and/or death, for which the manufacturer cannot be held responsible.



SAVE THIS INSTRUCTION MANUAL

Make sure everyone who's using or will be using the gate door opening system is aware of the dangers associated with this system. In case you will sell the property with the gate opener, Provided for copy of this manual to the new owner.



WARNINGS:

- Before starting the installation, check whether the product is suitable to automate your gate, If it is not suitable, DO NOT proceed with the installation.

Before installation:

Understand your new gate opener

- Read this instruction manual in advance to thoroughly understand its function and features.
- Verify that this gate opening system is proper for the type, size and weight of your gate.
- Check the state of your gate & pillars/ posts :
- Make sure that your gate has been properly installed and is functional.
- make sure the gate and post must be suitable for being automated.
- Check that the structure is sufficiently strong and rigid, and its dimensions and weights conform to the limits of the purchased gate opener.
- Make sure the leaves move smoothly without any irregular friction during entire travel.
- Make sure your gate is properly balanced and lubricated. An unbalanced gate could cause serious injury or death! Make sure the gate is plumb and level.
- The post must be secured in the ground with concrete. This will prevent alteration of alignments and leveling during installation and during cycles
- If the gate binds, sticks or is out of balance, before proceeding with gate opener installation, call a trained, certified gate technician to correct it and prevent serious injury or death.
- Repair or replace all worn or damaged gate components prior to installation. Call a trained professional gate technician for this.
- Make sure the hinges are in good condition. Ball bearing hinges are ideal for gates wings.
- To prevent damage to the gate and opening system, always disable the manual locks before installing and operating the opening system.

Prevent serious injury or death by electric power:

- Be sure the power is not connected BEFORE installing the gate opener control box
- NEVER connect the gate opener to the power source until instructed to do so.
- The gate opener installation and wiring MUST be in compliance with all local electrical and building codes

During installation

Ensure your personal safety:

- Never wear watches, rings or loose clothing while installing or servicing the opening system. They could get caught in the gate opener mechanisms.

- High voltage wiring (110V-230V power) must be done exclusively by a competent professional and certified electrician.

Prevent serious injury or death:

- Be careful when manipulating with moving parts and avoid close proximity to areas where fingers or hands could be pinched.
 - Use concrete anchors when installing any brackets into masonry.
 - Do not activate your gate opening system unless you are sure that the area of its travel is clear of persons, pets or other obstructions.
Watch the gate through its entire movement. Never leave childrens without parental control in proximity of a gate opener in motion, opened, closed or stopped.
 - Never permit children to play with remote control push buttons or transmitters of gate opener and prevent childrens to operate the gate opener by control push buttons or transmitters.
 - Always keep remote controls out of reach of children.
 - Install the electronic box of your opener out of reach of children and away of moving parts of the gate.
 - Activate the gate opener only when the gate can be seen clearly, is properly adjusted and there are no obstructions to gate travel.
 - Always keep gate in sight until completely closed.
- Prevent damage of the opening system and reduction of its safety features:
- The motor fixing brackets must be rigidly fastened to the pillar/wall/post and to a well reinforced part of the gate.
 - Never increase force beyond minimum amount required to close the gate.
 - Never use force adjustment to compensate for a binding or sticking gate.
- After any adjustment is made, the safety system must be tested.

After installation

- Install any fixed control at height of at least 1,5m and within sight of the gate but away from moving parts
 - Make sure you have a second pedestrian access to your property.
- Remember: in case of power failure or any problem with your opener you might be unable to operate it from outside your property
- Save the unlocking key in a safe place out of reach of childrens, in order to permit to manually unlock (from inside) the gate and operate it manually in case of power failure or other problem.

Verify correct installation:

- Ensure that the parts of the door do not extend over public footpath or roads
- Upon completion of installation, unlock the actuators and manually open and close the gate to check there's no mechanical friction and that it works correctly

DUCATI

How to install the actuator

- Make sure the gate wings stops on mechanical end limit fixed on the floor (not mandatory for FC actuators where mechanical limit stops is provided on board)
- SAFETY System in compliance with EU norms:
EN 12453 ENSURE SAFETY AND PREVENT ENTRAPMENT- CRUSHING
Any gate or garage door opener is required by the European Union to attend a series of strict and restrictive mandatory regulations which clearly regulate the automation industry.
Any new or existing installation requires a declaration of conformity issued by the manufacturer.
DUCATI not only self-certify his products, but also mandated International Notify body laboratories to perform full tests to certificate the compliance of the products to all applicables EN norms.
DUCATI ensure that the forces generated by a correctly installed gate opener, when touching a person or an obstacle are limited and that they do not exceed the values specified in Annex A of BS EN 12453:2001.

The final machine to be tested is composed by 2 fundamental elements: the structure (gate or garage door) and the automation device. This 2 elements compose the machine: automated electric gate/ automated electric gate system. Any new or existing installation requires a declaration of conformity issued by the final installer. The installer must test the final machine and attest the compliance to the latest European standards concerning impact forces in case of obstacle detection. Tests must be performed with a dinamoteter in precisely specified positions

Ensure safety and prevent injuries:

- Place warning sign of automated gate on the gate or next to it. Permanently fix a label warning against entrapment in a prominent place or just near any fixed control
- Without a properly working safety system, people (particularly small children) can be SERIOUSLY INJURED or KILLED by a closing door. After installation ensure that the mechanism is properly adjusted.
- Never permit anyone to cross the path of a closing gate.
- No one should go close to a stopped, partially open gate.
- Never leave children unsupervised near a gate opener, whether moving, open, closed or stopped.
- Never permit children to play with the gate opener's remote control buttons or transmitters, and do not allow children to use them to operate the gate opener.
Always keep remote controls out of reach of children.
- Install wall-mounted gate controls out of the reach of children and away from moving parts of the gate.
- Always keep the gate in sight until completely closed.

- While the gate is closing, do not attempt to stop it by hand. This is extremely dangerous.

MOUNTING HARDWARE:

To complete the installation you need at least following material:

- plastic hammer;
 - pinching for Seeger;
 - level;
 - frame fixing;
 - Cross screwdriver PH2;
 - flat screwdriver 2,5 mm;
 - adjustable wrench;
 - outdoor electric cable (2 poles) H07NRF length according to the connection of the two actuators to the control box;
 - 4 bolts for fixing plates with the gate with a diameter 8 mm length according to the thickness of the-gate;
 - 4 bolts for fixing plates with the pillar with a diameter 8 mm length according to the thickness of the pillar; pinching;
 - vice;
 - cable clamp.
 - Outdoor electric cables for additional accessories connections (0,5mmq)
- Prepare all the tools and material of use necessary to the installation.
Tools must be in perfect state and in conformity with the safety rules indicated by the national law.
Prepare and install an insulated underground ICT25 mm sheath to pass the actuator cable (2x1 mmq) to the control box as well as the photocells cables.

How to install the actuators

3. General installation diagram

The diagram on page 8 shows an example of a typical automatic system. Referring to this diagram, determine the approximate location where you will install each component envisaged in the system and the most appropriate connection diagram.

The actuators should preferably be installed at a height between the two gate hinges, and always in line with a reinforced horizontal cross of the gate to fix them in a structurally strong point. In case the gate is not provided with a reinforced horizontal cross, the gate structure must be reinforced at the actuator fixing point
The actuator should anyway never be installed less than 15 cm from the ground

The control unit box must be placed outside the reach of children and unauthorized persons, (at a suggested high of min. 1,2 m from the ground) preferably with a minimum distance of 60 cm from the actuators. If the control unit is not installed next to the gate but remotely, for example in a control room, an external radio receiver must be added to the system, which receives the radio signal in proximity of the gate.

The actuators must be connected to the main electronic board by a outdoor use bipolar electric cable H07NRF min 1 mmq.

The accessories must be connected with an outdoor use min. 0.5 mmq electric cable. (Cables, screws and dowels on the structure are not provided, but must be purchased separately according to the system and the specific material and dimension of the structure).

Automatic gate opener essential components

The minimum components needed to automate a swing gate are:

- 1= Control box with containing electronic board with on board radio receiver, toroidal transformer, inner battery compartment.
- 2 = actuators
- 3 = blinking light
- 6 = radio remote control

Useful additional components to complete the automatic gate system:



- 4 = external antenna
- 5 = key switch
- 7 = radio keypad
- 8 = solar panel
- 9 = pair of photocells (receiver + transmitter) & pair of photocells integrated in columns
- + GSM module and /or GSM Intercom to command your gate opener by your mobilephone

Gate opening towards inside (pull to open) or outside the property (push to open)

CAUTION: the most common types of gates are those with opening to the inside of the property. It is however also possible to automate gates that open out of the property following the following warnings:
to automate a gates that opens towards inside the property, it is necessary to use a compatible actuator model (telescopic actuators are recommended). check the

specific actuator diagram (page10-22) to verify it is compatible for installation on gate that opens towards outside.

NOTE: in the case of gate opening to the outside (PUSH-TO-OPEN) , it is necessary to reverse the polarity of motor cable wiring (check electronic wiring diagram of your electronic board model (page 36-52)
Check the feasibility of such a system considering the lateral overall dimensions. Make sure the gate wings do not open on a public passageway (This may be prohibited by specific national or local law, and you may be held liable for damages or injuries caused to third-party)
It is advisable to equip the system with a safety light barrier (photocells), which should be positioned so that the wings do not cause any damage or disturbance to any passing pedestrians, bikes or parked vehicles.

4. HOW TO INSTALL THE ACTUATOR:

The actuators must be installed inside your property.
First of all you should determine the height at which the actuators will be positioned. They should be preferably installed at a height between the two hinges, remember they must always match a reinforced horizontal cross of the gate to ensure the actuator is installed in a resistant part of the structure of your gate.

Warning: the actuator should never be installed less than 15 cm from the ground

Warning: the actuators must be installed horizontally in line with the gate: Check with a spirit level that the gate is perfectly balanced and make sure the drive is in balance with the gate. Take into account that if the actuator is not installed in line with the gate, it may cause a point of major friction during travel, incorrect operation and damages.

Identify the exact model of the actuator delivered in your gate opener package kit (see table page 4-5) and verify that the installation limits and the maximum A and B measures your structure must comply to be compatible with your actuator that your actuator are respected.

4.1 – Post mounting bracket

Pillar/ Column/ fence post: determinate the position where to install the post mounting bracket

According to the actuator model, and to the pillar/wall dimension, calculate the ideal fixing position of the rear bracket by consulting the installation schema of your

DUCATI How to install the actuator

actuator's model see diagram on page

HC 312.....	page 10
HC 412.....	page 11
HC 512.....	page 12
HC 612.....	page 13
HC 418.....	page 14
HC 518.....	page 15
HC 618.....	page 16
SW 400.....	page 17
SW 400T.....	page 18
EVO 700.....	page 19
EVO 700T.....	page 20
EVE 900.....	page 21
EVE 900 T.....	page 22

VERY IMPORTANT ADVICES:

 **WARNING:** The actuator should preferably have a **angle of incidence** to the closed gate and therefore not be perfectly parallel to the gate wing (see page 8). This will keep your gate well locked when the gate is closed, as the actuator will push the gate wing to the end stop with major force.

 **WARNING:** make sure **not to use the full actuator stroke** as the gate wing must stop by pressing on a mechanical end limit (fixed on the ground or FC integrated limit) before the actuator reaches the end of its own stroke travel (see page 8). In case of telescopic actuator it allows to keep the telescopic tube more guided when it is extroflexed, ensuring greater solidity.

 **WARNING:** In Gate opening towards inside the property (PULL-TO-OPEN) measures A & B shown in each actuator's diagram as well on page 9 are extremely important as they shall determinate the gate opening angle and speed as well as actuator thrust strenght. The shorter travel of the actuator's stroke is used, the greater the gate opening speed will be.

In general, smaller the A and B measurements, will result in higher gate opening speed.

Attention, it is recommended not to use a too high opening speed to avoid unwanted bumping rebounds at the end of the maneuver.

 **Where possible increase measure B to reduce speed.**
Important! to allow a linear movement of the automation A & B measures should be similar.

Warning: on double wing gates use same A & B measure on both sides.

To determine the most suitable mounting position, proceed as follows:

- Measure the depth of the the Post/ pillar column where your gate is installed to (measure from the center hinge to the inner edge of the column)
- After the depth of your post has been measured, compare it to maximal dimensions A and B indicated in the table of your actuator's model.

Warning: "B" measure is the sum of the depth of your pillar to center hinge + length of fixing brackets supplied.

Warning: the supplied post fixing brackets offer several holes choice.

- Select the hole where to fix the actuator to, accordingly to A & B measures limits.
- If necessary, cut away the excess of the bracket.

Warning: in some cases it will be necessary to get tailor-made post fixing brackets made by a blacksmith (for example in the case of round columns).

- Now determine the mounting position of the plate on the column, taking into account that the dimension B determines the maximum opening angle and the door opening speed. If this angle does not match your needs, you should re-adjust quote A and quote B so that they are similar.

Warning: Before securing the rear bracket and keeping the actuator in a perfectly horizontal and balanced position, perfectly horizontal supporting the engine, verify that the front fixing point of the actuator coincides with a solid and robust cross of the gate. Make sure that the actuator is mounted at a minimum height above the ground (min.15 cm are recommended) so that it is easy to operate the manual unlocking system.

Warning: in case your structure dimension do not allow to comply with the A& B dimensions stated in the actuator table & diagram (ex. large masonry pillar), you will need to carry out masonry works to allow the correct installation of the gate opener

Fix the bracket to the pillar/ coloumn/ fence post

Each actuator model is provided with specific fixing brackets.

Mark middle of post bracket slots on pillar/ coloumn/ fence post.

Fix the bracket on the pillar. Use suitable fastening bolts anchors (not supplied) suitable to the pillar construction material (iron post / concrete, brick or stone pillar).

Fix the actuator to the post bracket:

Fasten the actuator to the bracket of the rear fixing with the pin and seal ring

- for EVE actuators see pag..23
- for "HC" actuators see pag.24
- for "SW" & EVO actuators see pag.25

4.2 Front mounting bracket: How to determinate the position where to install the front mounting bracket

 **Warning:** make sure **not to use the full actuator stroke** (save at least 1-2cm of travel) as the gate wing must stop by pressing on a mechanical end limit (fixed on the ground or FC integrated limit) before the actuator reaches the end of it's own stroke travel (see page 8).
In case of telescopic actuator this allows to keep the telescopic tube more guided when it is extroflexed, ensuring greater solidity.

Suggestion: if it is necessary to move the actuator forward or backward, the motor can be powered directly with a 12V battery: connect the motor's two-pole cable to the two poles of the 12V battery. By inverting the polarity the motor reverses the direction of travel

Warning:

 **A) TELESCOPIC ACTUATORS,** featuring telescopic stainless steel telescopic tube are supplied with totally retracted piston tube, therefore the fixing position of the front bracket to the gate must be determined **with the gate in open position* (in case of gate opening towards inside the property)** or Vice versa in the case of a gate that opens outwards (push-to-open).

Resume of telescopic actuators models:
HC312; HC412; HC512; HC612; SW400T; EVO900T; EVE900T (+ corresponding 24V versions)

 **B) NOT TELESCOPIC ACTUATORS** are provided with running sleigh (sliding shoe plate) positioned to the front of the actuator, therefore the fixing position of the front bracket to the gate must be determined **with the gate in closed position* (in case of gate opening towards inside the property)** or Vice versa in the case of a gate that opens outwards (push-to-open).

Resume of NON telescopic actuators models:
HC418; HC518,HC618, SW400; EVO900; EVE900 (+ corresponding 24V versions)

Fix the front bracket to the gate

- The actuator must be fastened to the front fixing bracket, keep it perfectly in line with the gate wing

- bring the actuator to the gate leaf and identify the fixing point of the front plate to the wing gate.

- Mark middle of front bracket slots on the gate wing.

- Fix the bracket on the gate. Use bolts anchors or screws suitable for the gate (wood/ iron/...). It 'also possible to weld the bracket to the wing of the gate.

- Fasten the actuator to the bracket. Fix it with the pin and seal ring

- for "EVE actuators see page 23

- for telescopic "HC" actuators see page 24 drawing 19A

- for non- telescopic "HC" actuators see page 24 drawing 19B

- for telescopic "SW" and "EVO" actuators see page 25 drawing 25

- for non-telescopic "SW" and "EVO" actuators see page 25 drawing 24a/b

5. MANUAL RELEASE

The actuators are equipped with a release system which allows the manual handling of the gate in case of emergency.

The release system is operated through the use of three-sided key that must be inserted into the triangular slot.

Turn of about 180 ° up to the stop in a counterclockwise direction.

The actuators will be unlocked and the gate can be opened manually.

The reverse operation will restore the automatism traction.

Warning! perform the manual release only once the actuator is installed to the gate. The manual release could be little bit hard in the beginning, but after a run-in period will be smooth

- for EVE actuators see page 23

- for "HC" actuators see page 24

- for "SW" & EVO actuators see page 25

For "EVE" actuators the optional "EVE LOCK" manual release key protected accessory is also available. see page 23 fig. 15B

For "SW & EVO" actuators the optional "SW LOCK" manual release key protected accessory is also available. see page 25 fig.26B

In order to have access to the release system from the outside, it is advisable to create a secondary pedestrian passage, especially in the case where the gate does not allow access from the outside to the system.

6. Control maneuver.

Test of correct mechanical installation of the actuators on the gate

After installing the actuators, unlock them and perform some control maneuvers by manually moving the gate leaves. Make sure that the movement is smooth and continuous without any point of friction.

7 - MECHANICAL LIMITS

NOTE: the actuator will stop by amperometric detection system: it therefore requires mechanical stop limits to be installed on the floor to stop the gate wing in the open and closed position.

It is reminded that, with exemption in case of use of actuators featured with integrated mechanical or electrical limits, **it is mandatory to install mechanical gate stop limits to be firmly placed to the ground in correspondance to gate closed and open position (see page 4).**

The gate opener stops running by amperometric detection when the door detects and presses on the mechanical end limit.

FC actuator versions are equipped with integrated mechanical limits. for FC actuator versions, where the on-board limit is provided, it is not mandatory to have gate stops fixed to the ground.

- All actuators of the “EVE” series have a double mechanical end limits for “open” and “closed” gate position (see page 23 Fig. 16)
- SW, EVO and HC series actuators can be supplied in the special “FC” versions with integrated mechanical limit/ limits

WARNING:

HC; SW; EVO non telescopic actuators in FC version can be supplied with up to 2 integrated mechanical limit to set both open and closed gate position.

HC; SW; EVO telescopic actuators in FC version can be supplied with only one integrated mechanical limit.

For those actuators the integrated limit will set:

- the gate open position in case of gate opening toward inside (pull-to-open)
- the gate closed position in case of gate opening toward outside (push-to-open)

HOW TO ADJUST THE INTEGRATED END LIMIT (FC VERSIONS ONLY)

- #### 7.1 on board mechanical limits adjustment (for FC actuator’s versions only)
- Release the actuator
 - Manually place the gate wing in the open desired position. Hold the gate in the desired position.
 - Loosen the on-board mechanical stop ring’s screw with an Allen key
 - Slide the on-board mechanical stop ring along the large screw until it goes into contact with the nut screw (or sliding shoe plate)
 - stop & firmly tighten the limit switch by fastening the grains using an Allen key.
 - you can repeat the same procedure to adjust the second limit (if supplied) and set it for the gate leaf closed position.

7.2 on board electric limits adjustment (for EVE series in the “FCA” versions only)

Models: EVE in the “FCA” versions are equipped with 2 electric limits. To adjust the position of the limit switches use a flat screwdriver through the holes positioned in the front of the actuator. By turning the screws, you will adjust the electric limit along the stroke of the rod. The limits position is indicated on the side of the actuator by special marker

8. SAFETY AND END TEST

The manufacturer warrants that the gate openers, if correctly installed, and in accordance with the instructions manual, comply with the maximum obstacle thrust parameters specified in the European Standard EN 12445 ; EN 12453; EN 12635 and EN 13241-1.(Product’s compliance to the EU norms have been tested and certified by notify bodies such as Nemko and INTERTEK),

The installer of the gate opener to the gate is required to test the final machine to be in compliance with EU norms by using a dynamometer. The installer is required to issue the corresponding test certificate to the final user. Attention: the European Machinery Directive refers to the final structure and not to the gate opener only. Please note that the system consists of the gate opener (actuators+ kontrol board + accessories) + the structure on which the gate opener is installed on (gate-hinges, pillar/post/end limit). Each automated gate is therefore a unique machine and must therefore be tested and certified to be in compliance with EU or other national norms.

9. MAINTENANCE

The drives do not require any special maintenance. As a precaution and during intensive use, it is best to check the integrity of the electrical cable on the motor. Over time, it may be necessary to replace the carbon brushes (R15).

WARNING: NEVER USE GREASE LUBRICATE THE MECHANICAL PARTS!